



GESTAR®

The Solution!



HAND TOOL

Pliers / Locking Pliers / Cutter / Hammer
Punch / Measure / Clamp / Storage / Tool Set

7 DRAWER WAGON **with** **AUTO-REPAIRING TOOLS**

890-501



+PLUS

Drawer 1

Drawer 3

Drawer 2

Drawer 5

Drawer 4

Drawer 6

GESTARTOOL CO., LTD.
www.gestartec.com



Drawer 1

- 12 Sockets - 1/4" Dr. 6 Pt. :
4, 5, 5.5, 6, 7, 8, 9, 10, 11, 12, 13, 14 mm
- 11 Sockets - 1/4" Dr. 12 Pt. :
5/32", 3/16", 7/32", 1/4", 9/32", 5/16", 11/32",
3/8", 7/16", 1/2", 9/16"
- 12 Deep Sockets - 1/4" Dr. 6 Pt. :
4, 5, 5.5, 6, 7, 8, 9, 10, 11, 12, 13, 14 mm
- 4 E Sockets - 1/4" Dr. : E4, E5, E6, E8
- 21 Bit Sockets - 1/4" Dr. :
 - TORX® : T10, T15, T20, T25, T27, T30, T40
 - Hex : 3, 4, 5, 6, 7, 8 mm
 - ⊕ Phillips : PH1, PH2, PH3
 - Slotted : 4, 5.5, 6.5, 7, 8 mm
- 1/4" Dr. Quick Release Ratchet 6"
- 1/4" Dr. Flex Handle 6"
- 1/4" Dr. Extension 2" & 4"
- 1/4" Dr. Sliding T Bar 4-1/2"
- 1/4" Dr. Spinner 6"
- 1/4" Dr. Universal Joint
- 9 Pc. Ball End Hex Wrench Set, Metric, Long
- 9 Pc. TORX® Tamperproof Wrench Set, Long
- 3/8" Dr. Spark Plug Sockets : 16, 18, 21 mm
- 16 Sockets - 3/8" Dr. 6 Pt. :
6, 7, 8, 9, 10, 11, 12, 13, 14, 15, 17, 19, 20, 22,
23, 24 mm
- 18 Bit Sockets - 3/8" Dr. :
 - TORX® Tamperproof : T15, T20, T25, T27, T30,
T40, T45, T50
 - Hex : 5, 6, 7, 8, 10 mm
 - ⊕ Phillips : PH1, PH2, PH3
 - Slotted : 5.5 & 8 mm
- 3/8" Dr. Torque Wrench 14" 108 N-m (80 ft-lb)
- 3/8" Dr. Extension 3", 6", 8", 10"
- 3/8" Dr. Universal Joint
- 3/8" Dr. Flex Handle 8"
- 3/8" Dr. Sliding T Bar 8"
- 3/8" Quick Release Ratchet 8"
- 3/8" 2-Way L Handle 8"

Drawer 2

- 23 Sockets - 1/2" Dr. 6 Pt. :
8, 9, 10, 11, 12, 13, 14, 15, 16, 17,
18, 19, 20, 21, 22, 23, 24, 25, 26,
27, 28, 30, 32 mm
- 1/2" Dr. Flex Handle 15"
- 1/2" Dr. Extension 3", 5", 10"
- 1/2" Dr. Universal Joint
- 1/2" Quick Release Ratchet (Pear Head) 10"
- 1/2" Dr. Sliding T Bar 12"
- 17 Deep Sockets - 1/2" Dr. 12 Pt. :
10, 11, 12, 13, 14, 15, 16, 17, 18,
19, 20, 22, 23, 24, 27, 30, 32 mm
- 9 E Sockets - 1/2" Dr. :
E10, E11, E12, E14, E16, E18, E20,
E22, E24
- 1/2" Dr. Spark Plug Sockets : 16, 18, 21 mm

Drawer 3

- Impact Hex Bolster Screwdrivers :
 - ⊕ PH3 x 150mm L, PH2 x 100mm L
 - 8mm x 150mm L, 6.0mm x 100mm L
- Non-Slip Power Screwdrivers :
 - ⊕ PH1 x 75mm L, PH0 x 75mm L
 - 5.0mm x 75mm L, 3.2mm x 75mm L
- Stubby Screwdrivers :
 - ⊕ PH2 x 38mm L
 - 6.0mm x 38mm L
- Magnetic Bits Holder 4"
- Adjustable Wrench 10"
- Heavy Duty Curved Jaw Locking Pliers - 10"
- Snap Ring Pliers - External Straight Jaws 7"
- Snap Ring Pliers - Internal Straight Jaws 7"
- Snap Ring Pliers - External 90 Degree Bent Jaws 7"
- Snap Ring Pliers - Internal 90 Degree Bent Jaws 7"
- Slip Joint Pliers 8"
- Lineman's Pliers 8"
- Long Nose Pliers 7-1/2"
- Diagonal Cutting Pliers 7-1/2"
- Water Pump Pliers - Box Joint 10"
- Magnetic Power Nutsetter 1/4" Hex x 8mm Hex x 45mm L
- Ball-Lock Socket Adapter 1/4" Hex x 1/4" Sq. x 50mm L
- 13-Pc. Thickness Gauge

Drawer 4

- 8 Box End Wrenches - 12 Pt. :
6 x 7 mm, 8 x 9 mm, 10 x 12 mm,
11 x 13 mm, 14 x 17 mm, 19 x 21 mm,
21 x 23 mm, 22 x 24 mm
- 13 Thin Combination Wrenches - 12 Pt. :
6, 7, 8, 9, 10, 11, 12, 13, 14, 15, 16, 17, 19 mm
- 3 Flare Nut Wrenches - 6 Pt. :
8 x 9 mm, 10 x 11 mm, 10 x 12 mm
- 2 Adjustable Wrenches : 8" & 12"
- 12 Combination Wrenches - 12 Pt. :
20, 21, 22, 23, 24, 25, 26, 27, 28, 29, 30, 32 mm
- 6 Star Wrenches :
E6 x E8, E7 x E11, E10 x E12, E14 x E18,
E16 x E22, E20 x E24
- 4 Flare Nut Wrenches - 6 Pt. :
11 x 13 mm, 14 x 17 mm, 16 x 18 mm, 17 x 19 mm

Drawer 5

- 37 Impact Sockets - 1/2" Dr. :
8, 10, 11, 12, 13, 14, 15, 16, 17, 18, 19, 21, 22,
23, 24, 25, 26, 27, 29, 30, 32 mm
 - Hex Head : 5, 6, 8, 10, 12, 14, 17, 19 mm
 - TORX® : T25, T27, T30, T40, T45, T50, T55, T60
- 12 Deep Impact Sockets - 1/2" Dr. :
10, 11, 12, 13, 14, 15, 27, 30, 32, 34, 35, 36 mm
- 6 Thin Deep Impact Sockets - 1/2" Dr. :
17, 19, 21, 22, 23, 24 mm
- 1/2" Dr. Impact Extension 3" & 5"
- 1/2" Dr. Impact Universal Joint

Drawer 6

- Heavy Duty Pipe Wrench 12"
- Ball Pein Hammer 1 Lb.
- 2-Way Plastic Rubber Hammer

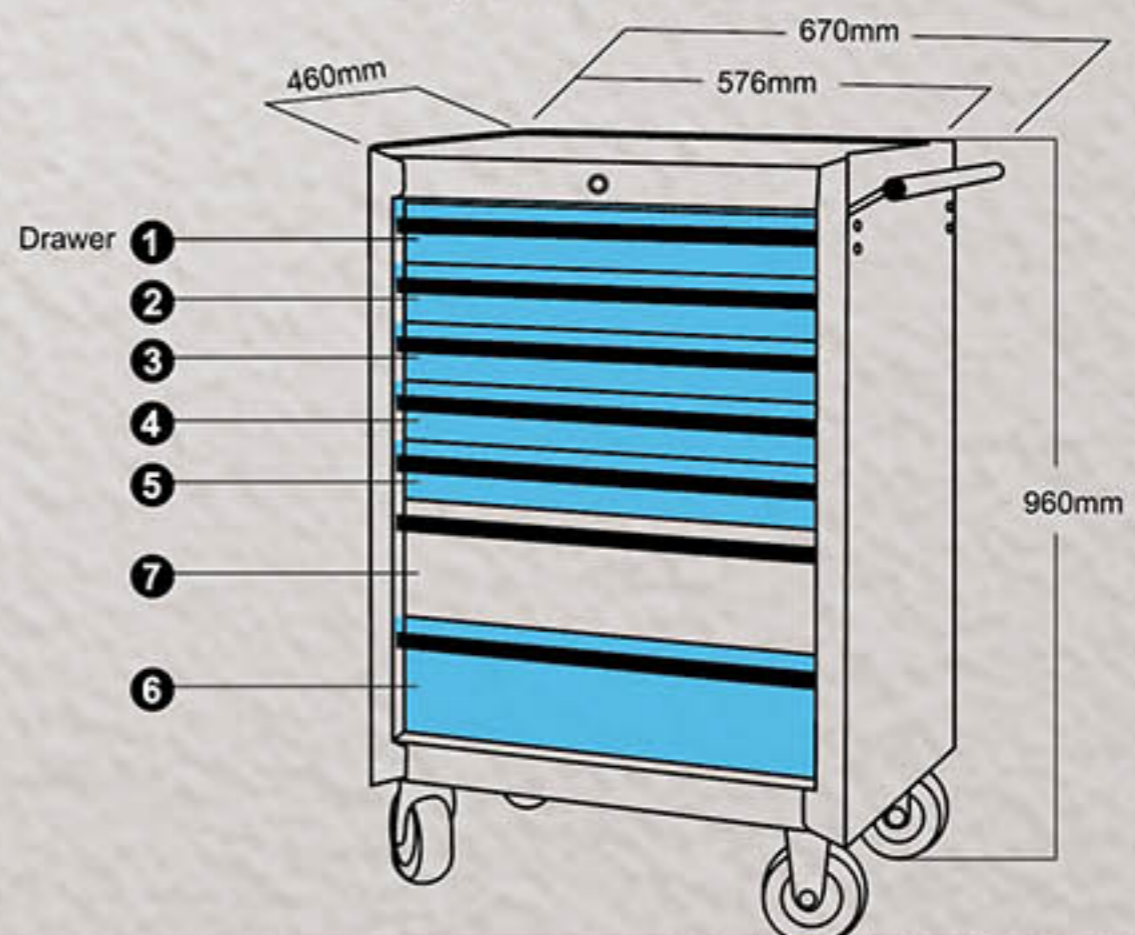

6 DRAWER WAGON

with AUTO-REPAIRING TOOLS

890-502

Drawer 1



- 16 Sockets - 3/8" Dr. 6 Pt. :
7, 8, 9, 10, 11, 12, 13, 14, 15, 16, 17, 18, 19,
20, 21, 22 mm
- 3/8" Dr. Quick Release Ratchet : Pear Head 8"
3/8" Dr. Extension 6" & 10"
3/8" Dr. Universal Joint
- 18 Sockets - 1/2" Dr. 12 Pt. :
8, 10, 11, 12, 13, 14, 15, 16, 17, 18, 19, 21, 22,
23, 24, 27, 30, 32 mm
- 1/2" Dr. Quick Release Ratchet : Pear Head 10"
1/2" Dr. Extension 10"
1/2" Dr. Universal Joint

Drawer 2



- 12 Socket - 1/4" Dr. 6 Pt. :
4, 4.5, 5, 6, 7, 8, 9, 10, 11, 12, 13, 14 mm
- 1/4" Dr. Quick Release Ratchet : Pear Head 6"
1/4" Dr. Extension 2" & 4"
1/4" Dr. Spinner 8"
1/4" Dr. Bit Adapter 1/4" Hex
1/4" Dr. Universal Joint 1-5/16"
- 16 Insert Bits 1/4" Hex x 25mm L :
● Slotted : 4, 5.5, 6.5 mm
⊕ Pozidriv : PZ1, PZ2, PZ3
○ Hex : 3, 4, 5, 6 mm
⊙ TORX® : T10, T15, T20, T25, T30, T40
- 9 Pc. Metric Hex Wrench Set, Ball End Long
- 3 Pin Punch: 4.0 x 9.5 x 150, 6.0 x 12.7 x 180, 8.0 x 12.7 x 180 mm
Flat Cold Chisel : 7/8" x 5/8" x 8"
Center Punch : 1/4" x 3/8" x 6"
Rubber and Plastic 2-Way Hammer : 35 mm
Ball Pein Hammer with Wood Handle : 16 oz

Drawer 3

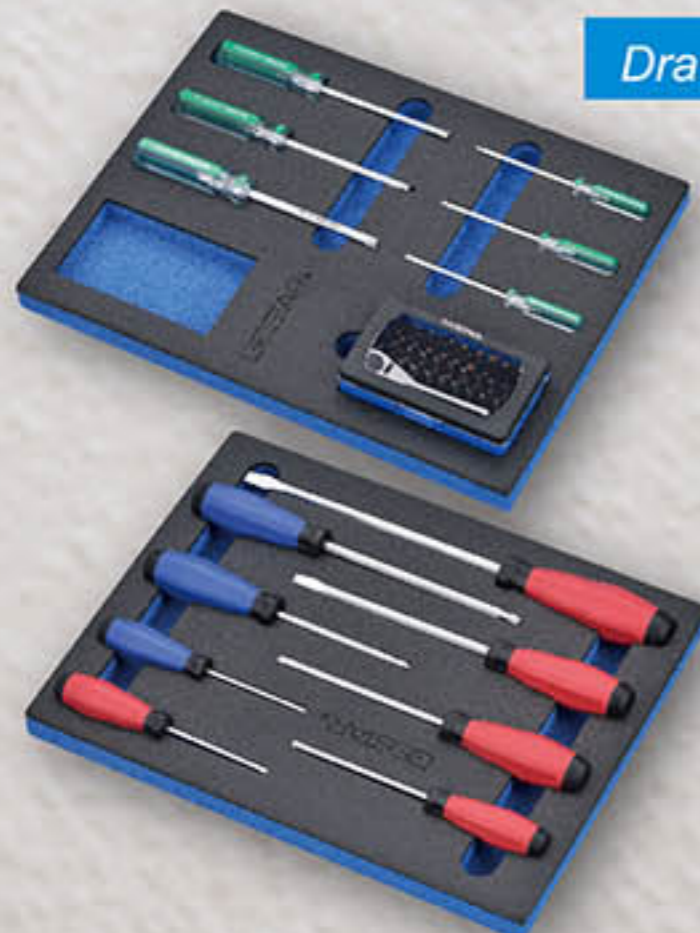

- Non-Slip Screwdriver :
● Slotted 3.2 mm x 75mm L, 4.0 mm x 100mm L,
5.0 mm x 125mm L, 6.0 mm x 150mm L,
8.0 mm x 200mm L
⊕ Phillips PH0 x 75mm L, PH1 x 100mm L,
PH2 x 150mm L
- Mechanical Screwdriver
○ TORX® T10 x 75mm L, T15 x 75mm L,
T20 x 75mm L, T25 x 100mm L,
T30 x 100mm L, T40 x 100mm L
- 30 Insert Bits : (1/4" Hex x 25mm L)
● Slotted : 3, 4, 5, 6 mm
⊕ Phillips : PH1, PH2, PH2, PH3
⊕ POZIDRIV® : PZ1, PZ2, PZ2, PZ3
○ Hex : 3, 4, 5, 6 mm
⊙ TORX® : T10, T15, T20, T25, T27, T30, T40
⊙ TORX® Tamperproof : T10, T15, T20, T25, T27, T30, T40
- 1/4" Ratchet Wrench

Drawer 4



Combination Wrench - 12 Pt. :
6, 7, 8, 9, 10, 11, 12, 13, 14, 15, 16, 17, 18,
19, 22, 24 mm
Angle Socket Wrench - 6 Pt. :
8, 10, 11, 12, 13, 14, 16, 17, 18, 19 mm

Drawer 5



Water Pump Pliers Box Joint 10"
Snap Ring Pliers - External Straight Jaws 7"
Snap Ring Pliers - Internal Straight Jaws 7"
Snap Ring Pliers - External 90 Degree Bent Jaws 7"
Snap Ring Pliers - Internal 90 Degree Bent Jaws 7"

Heavy Duty Curved Jaw Locking Pliers - 10"
Long Nose Pliers 7-1/2"
Diagonal Cutting Pliers 7-1/2"
Lineman's Pliers 8"
Wire Stripper Pliers 6"



■ 890-020

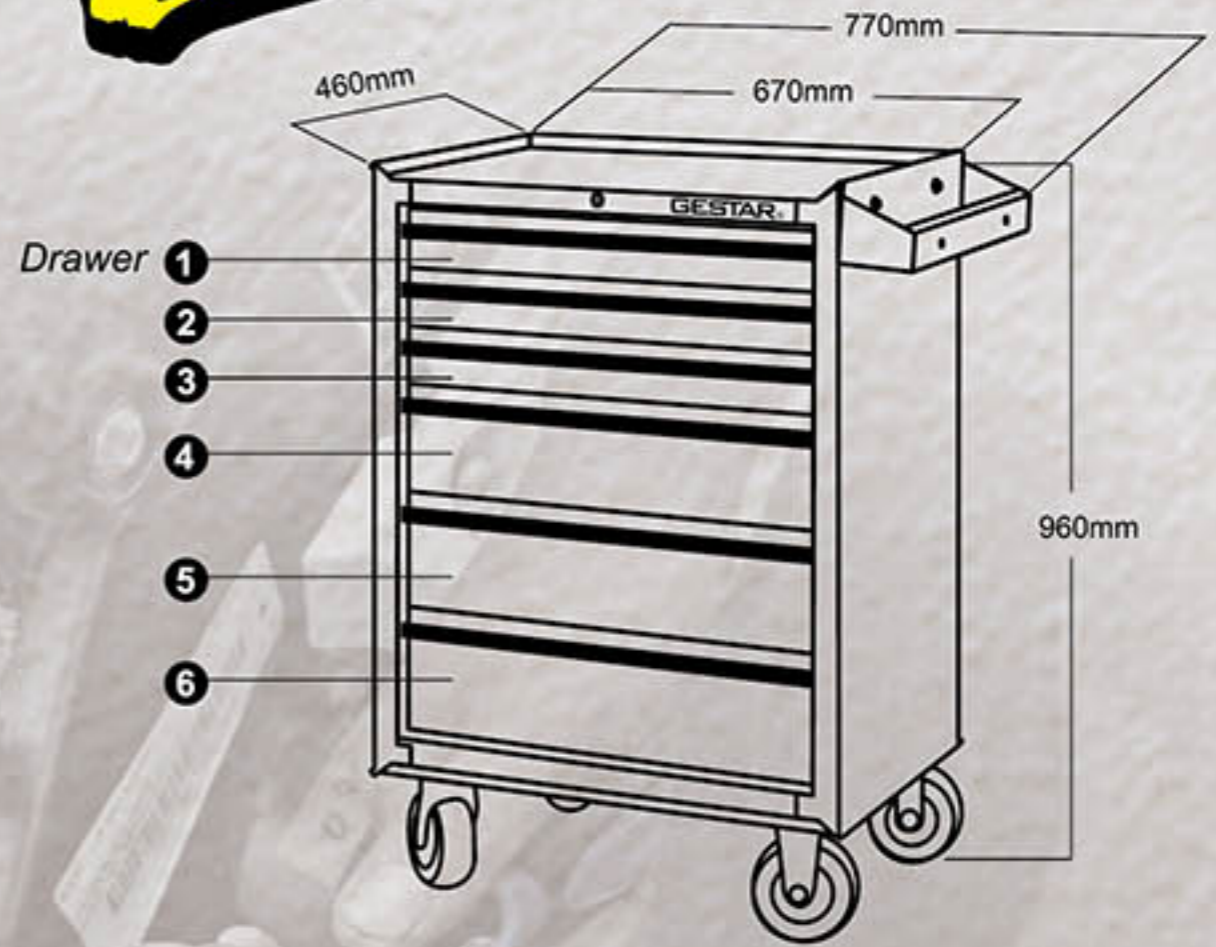

**999-060**

85 Pc. Tool Set

- ▶ 16 Sockets - 3/8" Dr., 6 Pt. :
9, 10, 11, 12, 13, 14, 15, 17, 19 mm &
3/8", 7/16", 1/2", 9/16", 5/8", 11/16", 3/4"
- 19 Sockets - 1/4" Dr., 6 Pt. :
4, 4.5, 5, 6, 7, 8, 9, 10, 11, 12 mm &
3/16", 7/32", 1/4", 9/32", 5/16", 11/32", 3/8", 7/16", 1/2"
- 20 Insert Bits - 1/4" Hex, 25mm L
 - Hex : 2, 3, 4, 5, 6 mm
 - Slotted : 3, 4, 5, 6, 7 mm
 - ⊕ Phillips : PH0, PH1, PH2, PH3
 - TORX® : T10, T15, T20, T25, T27, T30
 - 2 Plastic Bit Holders
- 9 Pc. Hex Wrench Set
- Measuring Tape : 5.0m
- 1/4" Dr. 2-Way L Handle 6"
- 1/4" Dr. 1/4" Hex Bit Adapter
- 3/8" Dr. Ratchet 8" Round Head
- 3/8" Dr. Extension 3"
- 3/8" F x 1/4" M Adapter
- 3/8" Dr. 1/4" Hex Bit Adapter
- 3/8" Dr. Spark Plug Socket 16mm (5/8")
- 1/4" Ratchet Screwdriver Handle

- ▶ Retractable Knife
- Claw Hammer with Wood Handle : 3/4 Lb.
- Adjustable Wrench : 8"
- ▶ Flat File : 8"
- Cushion Grip Screwdriver : ⊕ PH2 x 100mm L
- Cushion Grip Screwdriver : ● 6 x 100mm L
- 2-Way Stubby Screwdriver Set
- Lineman's Pliers : 7"
- Long Nose Pliers : 6-1/2"

AUTO-REPAIRING TOOLS

52 Pc. Tool Set

**999-000**

- ▶ 6 Open End Wrenches
6 x 7 mm, 8 x 9 mm, 10 x 12 mm, 12 x 14 mm, 14 x 17 mm, 17 x 19 mm
- 5 Box End Wrenches
8 x 9 mm, 10 x 12 mm, 12 x 14 mm, 14 x 17 mm, 17 x 19 mm
- 4 Combination Wrenches
10 mm, 12 mm, 14 mm, 17 mm
- ▶ 5 Cushion Grip Impact Hex Bolster Screwdrivers :
 - 6.0 x 100 mm, 8.0 x 150 mm, 8.0 x 200 mm
 - ⊕ PH2 x 100 mm, PH3 x 150 mm
- 2 Mechanical Screwdrivers : ● 4.0 x 200 mm, ⊕ PH0 x 75 mm
- 2 Stubby Screwdrivers : ● 6.0 x 38 mm, ⊕ PH2 x 38 mm
- ▶ Copper Hammer : 1 Lb.
- 2-Way Hammer (Rubber & Plastic) : 35mm
- Ball Pein Hammer : 3/4 Lb.
- Thickness Gauge : 0.03, 0.05, 0.06, 0.1, 0.25, 0.6, 0.7 mm
- L-Handle Socket : 10mm x 6"
- Snap Ring Pliers Internal Straight : 7"
- Snap Ring Pliers External Straight : 7"
- Slip Joint Pliers : 8"
- Long Nose Pliers : 6-1/2"
- Diagonal Cutting Pliers : 6-1/2"
- ▶ 5 T-Handle Sockets :
8mm (200 x 250 mm), 10mm (200 x 250 mm),
12mm (200 x 300 mm), 14mm (250 x 300 mm),
17mm (250 x 300 mm)
- 3 T-Handle Swivel Sockets :
10mm (200 x 600 mm), 12mm (200 x 600 mm),
14mm (200 x 600 mm)
- 2 T-Handle Spark Plug Sockets :
16mm (200 x 450 mm), 18mm (200 x 450 mm)
- 2 T-Handle Screwdrivers : ⊕ PH3 (180 x 250 mm)
● 8mm (180 x 250 mm)

MOTORCYCLE MECHANIC

50 Pc. Tool Set

999-001

7 Pc. Thickness Gauge Set

3/8" Dr. Bit Socket 4 Pc. :

○ TORX® : T40

○ Hex : 5, 6, 10 mm

Extension Bar 3 Pc. : 15 mm, 3", 10"

Socket Adapter : 3/8" F x 1/2" M

Sliding T Bar : 8"

Spark Plug Socket : 16 mm

Universal Joint

3/8" Dr. Socket 6 Pt. 7 Pc. : 10, 12, 14, 17, 19, 22, 24 mm

1/2" Dr. Socket 6 Pt. 2 Pc. : 30, 34 mm

T Handle Socket 6 Pt. : 8 mm

Open End Wrench 4 Pc. : 8 x 9, 10 x 12, 12 x 14, 17 x 19 mm

Box End Wrench 4 Pc. : 8 x 9, 10 x 12, 12 x 14, 17 x 19 mm

Combination Wrench 12 Pt. : 10 mm

75° Offset Box Wrench : 8 x 9 mm

Mechanical Screwdriver : ⚙ PH2 x 38mm L

Tappet Adjusting Wrench : Square 3 mm



Box End Wrench 12 Pt. : 22 x 24 mm

Copper Hammer : 16 Oz

Rubber and Plastic 2-Way Hammer : 35 mm

Snap Ring Pliers 2 Pc. : External Straight Jaws 7" &
Internal Straight Jaws 7"

Slip Joint Pliers : 8"

Long Nose Pliers : 6"

Mechanical Screwdriver : ⚙ 4.0 x 200mm L

Cushion Grip Impact Screwdriver 2 Pc. : ⚙ PH2 x 100mm L

⚙ 6.0 x 100mm L



High Leverage Lineman's Pliers

Item No.	Size		KGS
995-262	7"	5	1.5
995-266	8"	5	1.9
995-265	9"	5	2.1



High Leverage Long Nose Pliers

Item No.	Size		KGS
995-263	8"	5	1.4

High Leverage Diagonal Cutting Pliers

Item No.	Size		KGS
995-261	6"	6	1.4
995-267	7"	6	1.8

High Leverage Industry Diagonal Cutting Pliers

Item No.	Size		KGS
995-264	8"	5	1.4

High Leverage Engineer's Pliers

Item No.	Size		KGS
995-278	8"	6	1.9

HIGH LEVERAGE PLIERS



Specially designed leverage pivot generates larger torque, resulting in energy-saving and better performance.

High-leverage pliers offer more power than traditional pliers. Operation can be carried out with less energy.

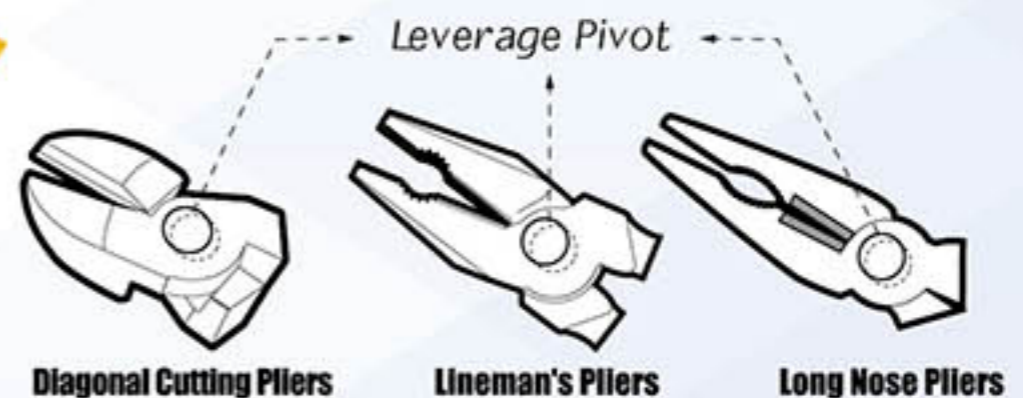



■ Multi-Function Lineman's Pliers

Item No.	Size		KGS
995-509	9"	5	2.5



■ Powerful Lineman's Pliers w/ Crimping Die

Item No.	Size		KGS
995-549	9-1/2"	5	2.6



■ Lineman's Pliers

Item No.	Size		KGS
995-306	6"	5	1.2
995-307	7"	5	1.5
995-308	8"	5	1.9



■ Electrician's Pliers w/ Wire Stripper

Item No.	Size		KGS
995-528	8-1/2"	5	1.5



■ Multi-Function Crimping Die Cutting Pliers

Item No.	Size		KGS
995-538	8"	5	1.5



■ Long Nose Pliers

Item No.	Size		KGS
995-105	5-1/2"	5	0.7
995-106	6-1/2"	5	0.9
995-108	7-1/2"	5	1.3



■ Diagonal Cutting Pliers

Item No.	Size		KGS
995-205	5-1/2"	5	0.9
995-206	6-1/2"	5	1.0
995-207	7-1/2"	5	1.4

For Cutting Plastic And Lead Edges • With Curved:
For Removing Burr From Curved Surface



INDUSTRIAL PLIERS

Heavy duty tool for industrial applications. Ergonomically designed to fit right to your palm, and makes every application effectively with comfortable handling.

The industrial graded series is made with long lasting operation life.

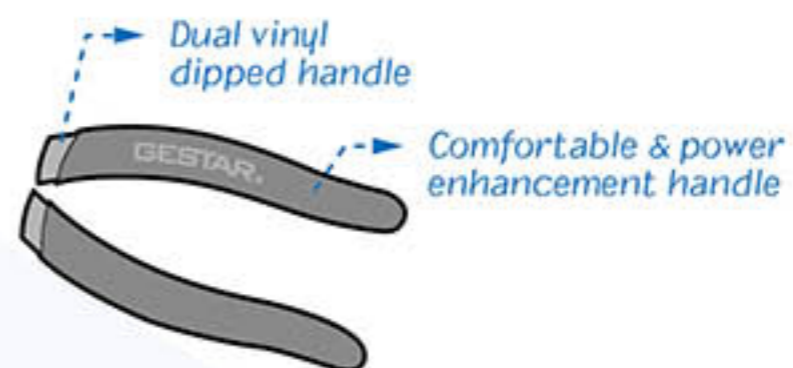

Multi-Function Lineman's Pliers

Item No.	Size		KGS
995-519	9"	5	2.9

Powerful Lineman's Pliers w/ Crimping Die

Item No.	Size		KGS
995-569	9-1/2"	5	3.3

Lineman's Pliers

Item No.	Size		KGS
995-316	6"	5	1.5
995-317	7"	5	1.8
995-318	8"	5	2.3



Electrician's Pliers w/ Wire Stripper

Item No.	Size		KGS
995-548	8-1/2"	5	1.6

Multi-Function Crimping Die Cutting Pliers

Item No.	Size		KGS
995-558	8"	5	1.9

Long Nose Pliers

Item No.	Size		KGS
995-115	5-1/2"	5	1.1
995-116	6-1/2"	5	1.1
995-118	7-1/2"	5	1.7

Diagonal Cutting Pliers

Item No.	Size		KGS
995-215	5-1/2"	5	1.0
995-216	6-1/2"	5	1.3
995-217	7-1/2"	5	1.8

3 Pc. Pliers Set

Item No.		KGS
995-403	9	7.2

- 6-1/2" Diagonal Cutting Plier
- 6-1/2" Long Nose Plier
- 7" Lineman's Plier



■ Side Cutting Pliers

Item No.	Size		KGS
995-255	5"	6	0.7
995-256	6-1/2"	6	0.9

For Cutting Plastic And Lead Edges

- With Angle:
For Removing Burr From Flat Surface



■ Slip Joint Pliers

Item No.	Size		KGS
995-406	6"	5	1.1
995-408	8"	5	1.4
995-410	10"	5	2.0

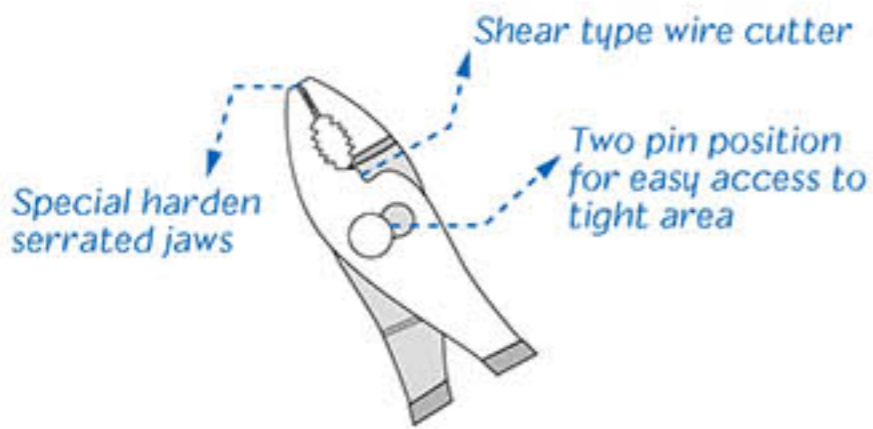

■ Water Pump Pliers

Item No.	Size		KGS
995-808	8"	5	1.0
995-810	10"	5	1.7
995-812	12"	5	2.7

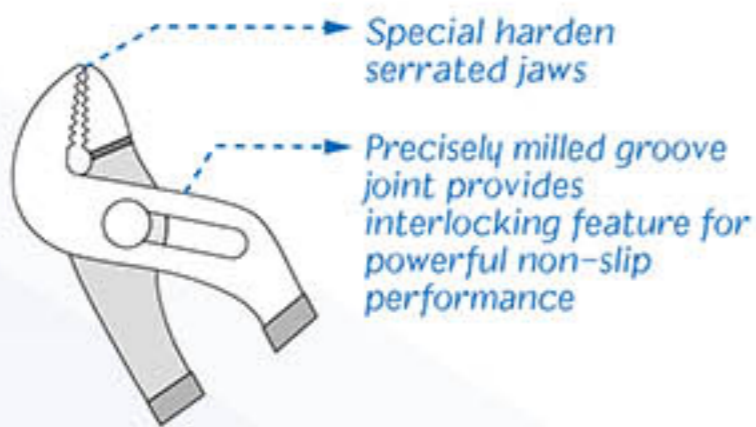

■ Water Pump Pliers – Box Joint

Item No.	Size		KGS
995-817	8"	6	0.9
995-818	10"	6	1.8
995-819	12"	6	2.7



■ Snap Ring Pliers – External Straight Jaws

Item No.	Size	Capacity		KGS
995-151	7"	19-60 mm	5	1.0
995-191	9"	40-100 mm	5	1.6

■ Snap Ring Pliers – Internal Straight Jaws

Item No.	Size	Capacity		KGS
995-152	7"	10-45 mm	5	1.0
995-192	9"	32-80 mm	5	1.6

■ Snap Ring Pliers – External 90 Degree Bent Jaws

Item No.	Size	Capacity		KGS
995-153	7"	19-60 mm	5	1.0
995-193	9"	40-100 mm	5	1.6

■ Snap Ring Pliers – Internal 90 Degree Bent Jaws

Item No.	Size	Capacity		KGS
995-154	7"	19-60 mm	5	1.0
995-194	9"	40-100 mm	5	1.6

■ 4 Pc. Snap Ring Pliers Set

Item No.	Size		KGS
995-405	7"	8	5.3

- External Straight Jaws Capacity : 19-60 mm
- Internal Straight Jaws Capacity : 10-45 mm
- External 90 Degree Bent Jaws Capacity : 19-60 mm
- Internal 90 Degree Bent Jaws Capacity : 19-60 mm

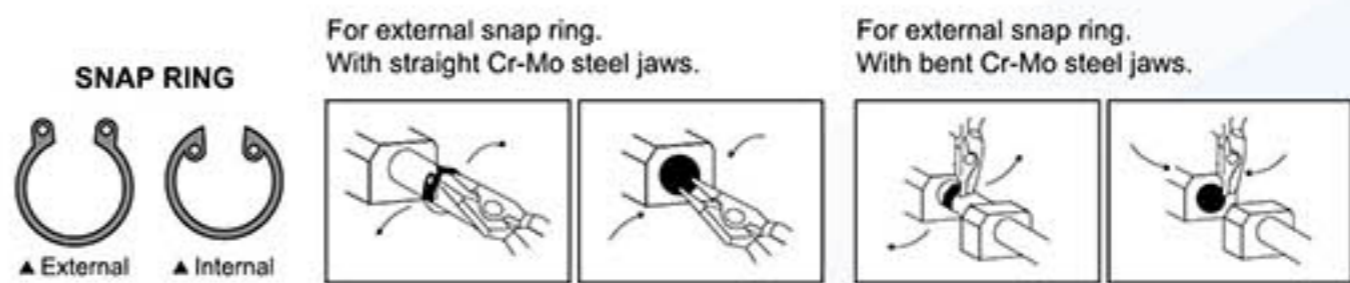

6 in 1 Snap Ring Pliers Set

Item No.		KGS
894-006	12	2.7

- Interchangeable 45°, 90° and Two Straight Heads





■ Insulated Combination Pliers

Item No.	Size			KGS
995-321	6"	1000 V	12	2.3
995-320	8"	1000 V	12	4.6



■ Insulated Diagonal Cutting Pliers

Item No.	Size			KGS
995-218	6"	1000 V	12	2.9



■ Insulated Long Nose Pliers

Item No.	Size			KGS
995-119	6"	1000 V	12	2.3



■ Insulated Wire Strip Pliers

Item No.	Size			KGS
995-123	6"	1000 V	12	2.8

- VDE insulated, ideal for working up to 1000 V AC
- Soft grip handles for enhanced grip and control
- Chrome vanadium steel offering excellent durability and corrosion



Safety Wire Twisting Pliers

Item No.	Size		KGS
895-419	6"	100	26.5
895-421	9"	50	19.5

- For all kind of wire-twisting applications where vibration may cause fastener to back out.
- Side cutter for cutting stainless.
- Slim nose tip allows access in tight work areas.
- Automatic spring mechanism for efficient operation and less fatigue.

Terminal Crimping Pliers

Item No.	Size	For Terminals		KGS
895-281	7"	1.25, 2, 3.5, 5.5 mm ²	6	1.8
895-282	10-1/2"	1.25, 2, 3.5, 5.5, 14 mm ²	6	3.2
895-283	14"	5.5, 14, 22, 38 mm ²	4	3.0

- Suited for terminal types :
Ring terminal, Y terminal, Pin terminal, Non-Insulated terminal, Copper tube terminal, Cable lugs 1-hole, Cable lugs 2-hole.

Wire Stripper Pliers

Item No.	Size		KGS
995-136	6"	5	1.2

Material : Carbon steel, Drop forged, entirely hardened and tempered. Cutting edges induction hardened.
Stripping capacity: up to max 0.6 - 10mm²



Multi-Function Automatic Wire Stripper

Item No.	Size		KGS
994-983	8"	10	3.6

Longer grip handle designed leverage point for use less force to strip, cut and crimp.

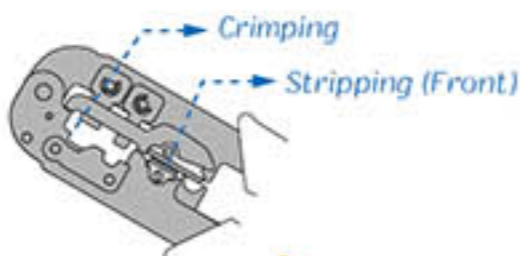
- Application :
- Strippable cable wire : 0.2 ~ 6mm² (10 - 22AWG)
 - Cut cable wire : 0.2 ~ 6mm²
 - Crimping terminal : 0.5 ~ 6mm²

Multi-Function Modular Crimping Tool

Item No.	Size		KGS
894-931	7-1/2"	10	3.0

Telephone network crimping, suitable for Crystal heads :
8P8C(RJ45), 6P6C(RJ12), 6P4C(RJ11), 4P4C & 4P2C

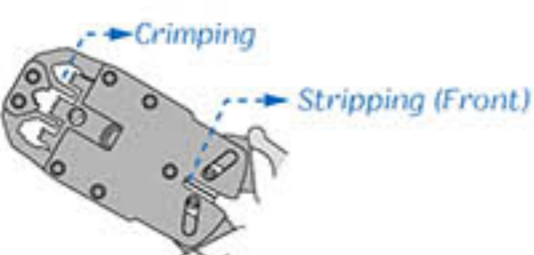
Ratcheting Multi-Function Modular Crimping Tool

Item No.	Size		KGS
894-941	8"	10	5.7

Telephone network crimping, suitable for Crystal heads :
8P8C(RJ45), 6P6C(RJ12), 6P4C(RJ11), 4P4C & 4P2C



■ Miniature Bolt Cutter

Item No.	Size		KGS
994-308	8"	6	2.5



■ Bolt Cutter

Item No.	Size		KGS
994-314	14"	1	1.1
994-318	18"	1	1.6
994-324	24"	1	2.6
994-330	30"	1	4.2
994-336	36"	1	5.5
994-342	42"	1	8.0



■ Cable Cutter

Item No.	Size		KGS
995-021	6"	6	1.2
995-022	8"	5	1.6
995-023	10"	6	2.4



■ Heavy Duty Cable Cutter

Item No.	Size		KGS
995-027	10"	6	3.3



■ Ratchet Cable Cutter

Item No.	Size	Application		KGS
894-350	10"	600MCM (240mm ²)	20	15.6
894-351	11"	750MCM (400mm ²)	10	12.2

Blade hardness : HRC45~47*



■ PVC Pipe Cutter

Item No.	Capacity Pipe OD	Max Pipe Size		KGS
894-912	42 mm (1-5/8")	1-1/4"	10	4.3

1. Release the safety ring and pull the handles all the way apart.
2. Set the pipe in the opening and begin to ratchet it.
3. With each squeeze, another round is engaged. And the blade can be pushed down a little more.
4. Repeat step 3 till the tube is cut.

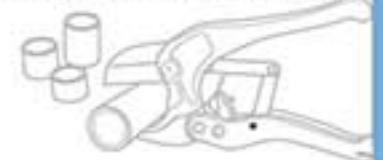

■ Heavy Duty PVC Pipe Cutter

Item No.	Capacity Pipe OD	Max Pipe Size		KGS
894-913	42 mm (1-5/8")	1-1/4"	48	23.0

Automatically open ,ratchet cutting for ease of use. L : 225mm



■ Flat Band Hose Clamp Pliers

Item No.	Size		KGS
895-042	8-1/2"	12	2.4

Use to remove and install flat band hose clamps used on heater and radiator hoses. Tips screw in and out to fit all clamp sizes



Heavy Duty Locking Pliers, Curved Jaw

Item No.	Size		KGS
994-155	5"	5	0.9
994-157	7"	10	3.6
914-010	10"	5	3.0



Heavy Duty Locking Pliers, Straight Jaw

Item No.	Size		KGS
994-167	7"	10	3.6
994-550	10"	5	3.1



Locking Pliers, Curved Jaw

Item No.	Size		KGS
894-105	5"	10	2.2
894-107	7"	6	2.4
894-110	10"	5	2.7



Locking Pliers, Straight Jaw

Item No.	Size		KGS
894-505	5"	10	1.8
894-507	7"	6	2.4
894-510	10"	5	2.9

LOCKING PLIERS

Constructed of high-grade heat-treated alloy steel for maximum toughness and durability. Ideal for awkward shaped pieces. Turn screw to adjust pressure and fit work. Stays adjusted for repetitive use. Guarded release trigger quickly unlocks and protects from accidental release.

Clamping power vs. structure = Rigidity (tight or loosen)+over-center action

Helical Curved Jaw

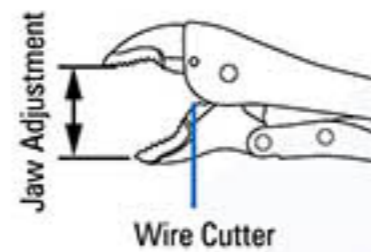
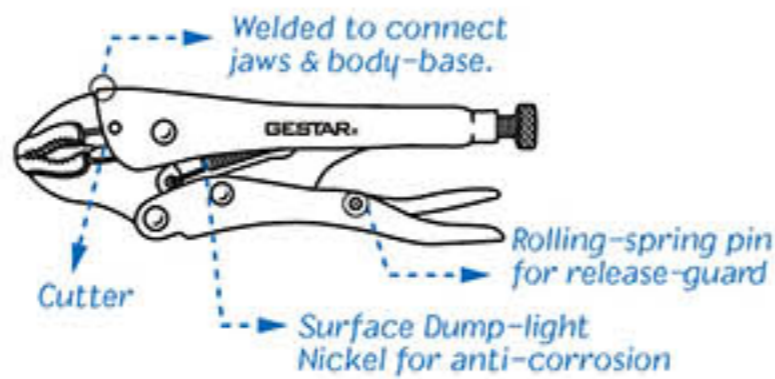

Straight Jaw

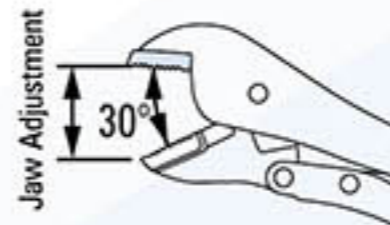
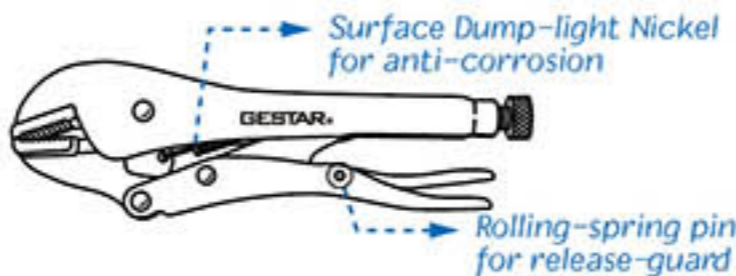

Usage & Operation:

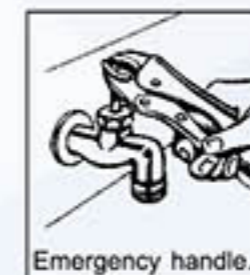

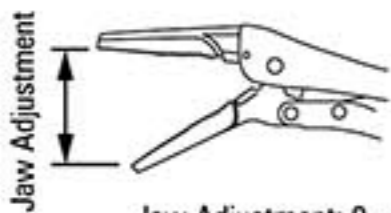

Jaw Adjustment: 0~1-5/8" (0~41.3 mm)

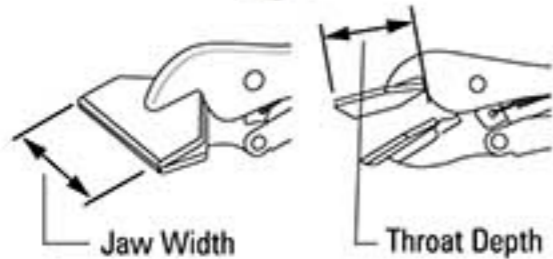

Jaw Width: 0~3-1/8" (0~79.4 mm)
Throat Depth: 1-3/4" (44.5 mm)

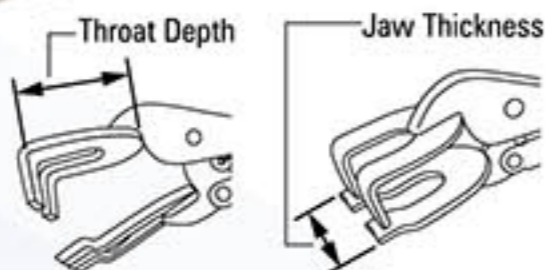

Throat Depth: 2-3/16" (55.5 mm)
Jaw Thickness: 0~2-3/4" (0~69.8 mm)



Heavy Duty Long Nose Locking Pliers

Item No.	Size		KGS
994-176	6"	10	3.6

Long Nose Locking Pliers

Item No.	Size		KGS
894-406	6"	12	2.4
894-409	9"	12	4.8



For small piece ...



Use as wrench ...



Cut wire ...

Heavy Duty Locking Metal Sheet Clamp

Item No.	Size		KGS
994-188	8"	1	0.5



Double crimp workpieces together for further operation.



Lock and bend workpiece with powerful grip.

Heavy Duty Locking Welding Clamp

Item No.	Size		KGS
994-239	9"	1	0.6

Locking Welding Clamp

Item No.	Size		KGS
994-241	11"	1	0.8



U-shaped jaws hold tightly and securely on any round materials.



Also lock versatile shaped materials for drilling, plumbing, welding and other applications.

Heavy Duty Locking Chain Clamp

Item No.	Size		KGS
994-280	20"	1	0.8



Holds multiple and/or odd-shaped workpieces with chain clamp.



Heavy Duty Locking C Clamp

Item No.	Size		KGS
994-246	6"	5	1.2
994-251	11"	5	4.3
994-258	18"	1	1.1

Locking C Clamp

Item No.	Size		KGS
894-436	6"	5	1.0
894-441	11"	5	3.7
894-448	18"	1	1.5

Heavy Duty Locking C Clamp With Swivel Pads

Item No.	Size		KGS
994-266	6"	5	1.2
994-271	11"	5	4.3
994-278	18"	1	1.5

Locking C Clamp with Swivel Pads

Item No.	Size		KGS
894-456	6"	5	1.4
894-461	11"	5	4.5
894-468	18"	1	1.6



LOCKING C-CLAMP

Unlike the design in most of other locking pliers, the upper jaw is hooked on the body, then is welded together. This assembly configuration enhance rigidity and strengthens clamping power.





AVIATION SNIPS

- Cuts cold-rolled steel up to 1.2mm or stainless steel up to 0.7mm
- Auto release mechanism for one handed operation
- Cr-Mo blades add strength and durability
- Serrated blade design provide a sturdy bite
- Color-coded slip-resistant grip



Blow Mold Box

Aviation Snips – Left Cutting

Item No.	Size		KGS
894-921	10"	6	2.9

Aviation Snips – Right Cutting

Item No.	Size		KGS
894-922	10"	6	2.9

Aviation Snips – Straight Cutting

Item No.	Size		KGS
894-923	10"	6	2.9

Usage & Operation:

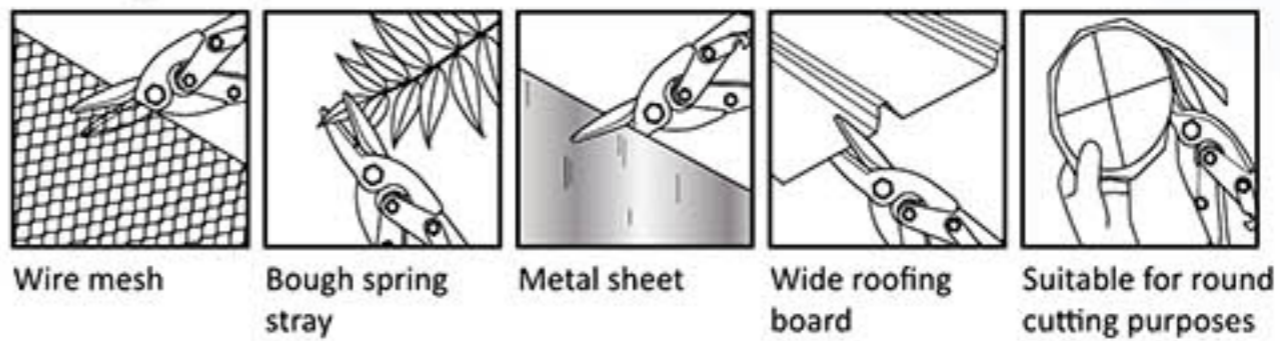

Plastic Retractable Utility Knife

Item No.		KGS
868-801	15	2.1

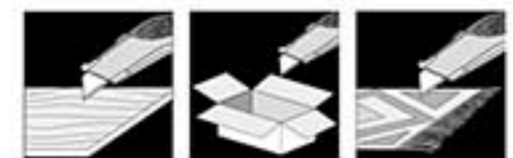
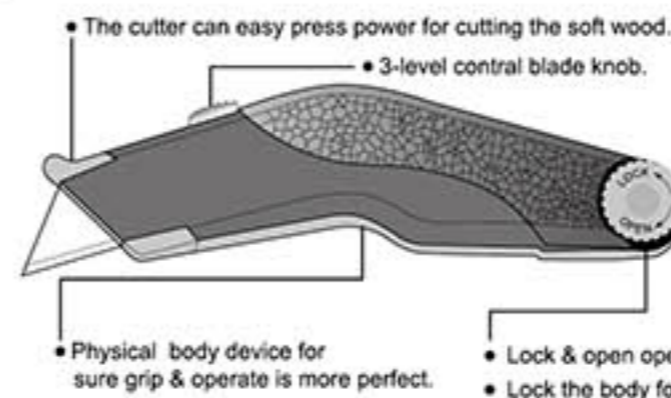

WARNING:
The knives should be used for cutting only.

- Lock & open operate knob, can be open the body and load the extra blade.
- Lock the body for sure the body this close and can be safety operat.

Zinc Alloy Utility Knife

Item No.		KGS
868-802	15	3.5



WARNING:
The knives should be used for cutting only.

- Lock & open operate knob, can be open the body and easy load the extra blade.
- Lock the body for sure the body this close and can be safety operat.

Flaring & Tubing Cutter Tool Kit

Item No.		KGS
895-760	1	1.8

- Flares : 1/4", 4.75, 5, 6, 8 & 10 mm O.D.
- Tube Cutter : 1/8" - 1-1/8" (3-28 mm) O.D.
- Stell Forged Yoke : 25/32"
- Swages : 1/2", 1/4", 6, 8 & 10 mm O.D.

Claw Hammer with Wood Handle

Item No.	Head Weight		KGS
968-108	8 OZ	6	2.3
968-112	12 OZ	6	3.4
968-116	16 OZ	6	4.2
968-120	20 OZ	6	5.0

Claw Hammer with Fiberglass Handle

Item No.	Head Weight		KGS
968-208	8 OZ	6	2.6
968-212	12 OZ	6	3.5
968-216	16 OZ	6	4.4
968-220	20 OZ	6	5.0
968-224	24 OZ	6	4.5



Ball Pein Hammer with Wood Handle

Item No.	Head Weight		KGS
968-308	8 OZ	6	1.7
968-312	12 OZ	6	2.8
968-316	16 OZ	6	3.0
968-324	24 OZ	6	4.5
968-332	32 OZ	6	5.9
968-340	40 OZ	6	6.8
968-348	48 OZ	6	8.0

Ball Pein Hammer with Fiberglass Handle

Item No.	Head Weight		KGS
969-308	8 OZ	6	1.8
969-312	12 OZ	6	2.7
969-316	16 OZ	6	3.1
969-324	24 OZ	6	4.5
969-332	32 OZ	6	6.3

Rubber and Plastic 2-Way Hammer

Item No.	Diameter		KGS
968-511	25 mm	6	1.0
968-512	30 mm	6	1.5
968-513	35 mm	6	2.3
968-514	40 mm	6	2.5



■ Engineer's Hammer

Item No.	Head Weight		KGS
968-831	100 Grams	6	0.8
968-832	200 Grams	6	1.4
968-833	300 Grams	6	2.1
968-834	400 Grams	6	3.3
968-835	500 Grams	6	3.8
968-836	600 Grams	6	4.8
968-838	800 Grams	6	5.2



■ Sledge Hammer with Hard Wood Handle

Item No.	Head Weight		KGS
968-401	1 Lb.	6	3.1
968-402	2 Lb.	6	5.7
968-404	4 Lb.	1	1.7
968-406	6 Lb.	1	3.2
968-408	8 Lb.	1	4.1
968-410	10 Lb.	1	4.7
968-412	12 Lb.	1	5.6
968-414	14 Lb.	1	6.0
968-416	16 Lb.	1	8.1
968-420	20 Lb.	1	9.6



■ Copper Hammer

Item No.	Head Weight		KGS
968-712	12 OZ	8	3.1
968-716	16 OZ	6	3.3
968-724	24 OZ	6	4.7
968-732	32 OZ	6	6.0



■ Rubber Hammer Mallet

Item No.	Head Weight		KGS
968-931	8 OZ	6	1.5
968-932	12 OZ	6	2.7
968-933	16 OZ	6	3.0
968-934	24 OZ	6	5.5
968-935	32 OZ	6	5.2



Stone Hammer with Hard Wood

Item No.	Head Weight		KGS
968-431	2.2 Lb.	6	6.0
968-432	2.75 Lb.	6	8.4
968-433	3.3 Lb.	6	8.7
968-434	4.4 Lb.	6	13.2

Dead Blow Hammer

Item No.	Head Weight		KGS
969-511	1 Lb.	6	3.9
969-512	2 Lb.	6	5.5
969-513	3 Lb.	6	8.1

Gasket Scraper

Item No.	Size		KGS
967-501	7"	6	0.5

Wood Chisel

Item No.	Size		KGS
967-102	1/4"	6	1.2
967-104	1/2"	6	1.3
967-106	3/4"	6	1.5
967-110	1"	6	1.6
967-114	1-1/2"	6	2.0

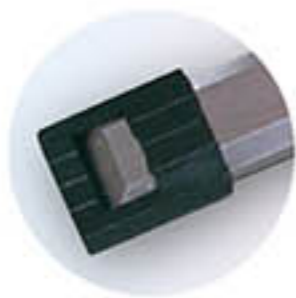

▲ A plastic safety lid to prevent
From hurt by sharp blade

Cape Cold Chisel

Item No.	Point x Hex x Length		KGS
884-921	5 x 9.5 x 140 mm	20	1.4

Cape chisels, or slot chisels, are used to cut flat grooves for keyways or slots. The cutting end tapers to a flat cutting end for precise cuts.

■ Flat Chisel (Cold Chisel)



Item No.	Point x Hex x Length		KGS
SAE			
884-901	3/8" x 5/16" x 5-1/2"	20	0.1
884-902	1/2" x 7/16" x 6"	20	1.9
884-905	5/16" x 1/4" x 5"	20	2.0
884-906	1/2" x 7/16" x 6-1/2"	20	2.0
884-907	5/8" x 1/2" x 6-1/2"	20	2.5
884-908	3/4" x 5/8" x 7"	20	2.5
884-909	7/8" x 5/8" x 8"	20	3.0

Used for remove metal from large flat surfaces and chip-off excess metal of welded joints and castings.

■ Center Punch



Item No.	Point x Hex x Length		KGS
SAE			
884-601	1/8" x 5/16" x 5"	20	1.5
884-603	5/32" x 5/16" x 5-1/2"	20	1.5
884-602	3/16" x 7/16" x 6"	30	3.0
884-604	1/4" x 3/8" x 6"	20	3.0

Center punches are used for piercing, marking or starting drills in metal and other materials. The points differ to achieve the most appropriate hole size.

■ Pin Punch

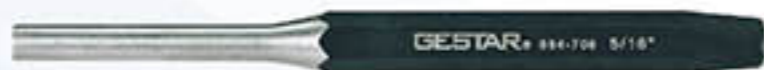

Item No.	Point x Hex x Length		KGS
Metric			
884-662	2.0 x 8 x 115 mm	20	1.0
884-663	3.0 x 8 x 125 mm	20	1.0
884-664	4.0 x 9.5 x 150 mm	20	1.5
884-665	5.0 x 9.5 x 165 mm	20	1.5
884-666	6.0 x 12.7 x 180 mm	20	2.0
884-668	8.0 x 12.7 x 180 mm	20	2.0
SAE			
884-708	1/16" x 1/4" x 4-1/4"	60	1.3
884-701	3/32" x 1/4" x 4-1/4"	60	1.3
884-702	1/8" x 5/16" x 4-3/4"	40	1.4
884-703	5/32" x 3/8" x 5"	20	1.0
884-704	3/16" x 3/8" x 5-1/4"	20	1.0
884-707	1/4" x 3/8" x 5-3/4"	20	1.7
884-705	1/4" x 7/16" x 5-3/4"	20	1.7
884-706	5/16" x 1/2" x 6-1/4"	20	2.4

Pin punches are used to drive out and remove loosened pins and keys, not for seized pins and keys.

Starting Punch

Item No.	Point x Hex x Length		KGS
SAE			
884-801	3/32" x 5/16" x 5-1/2"	20	0.9
884-802	1/8" x 3/8" x 5-3/4"	20	1.3
884-803	5/32" x 3/8" x 6"	20	1.5
884-804	3/16" x 7/16" x 6-1/4"	20	2.1
884-805	1/4" x 1/2" x 6-3/4"	20	2.6
884-806	5/16" x 1/2" x 7-1/4"	20	3.0

Starting punches are used to scribe lines in metal before cutting or riveting. The point sizes vary for different widths.

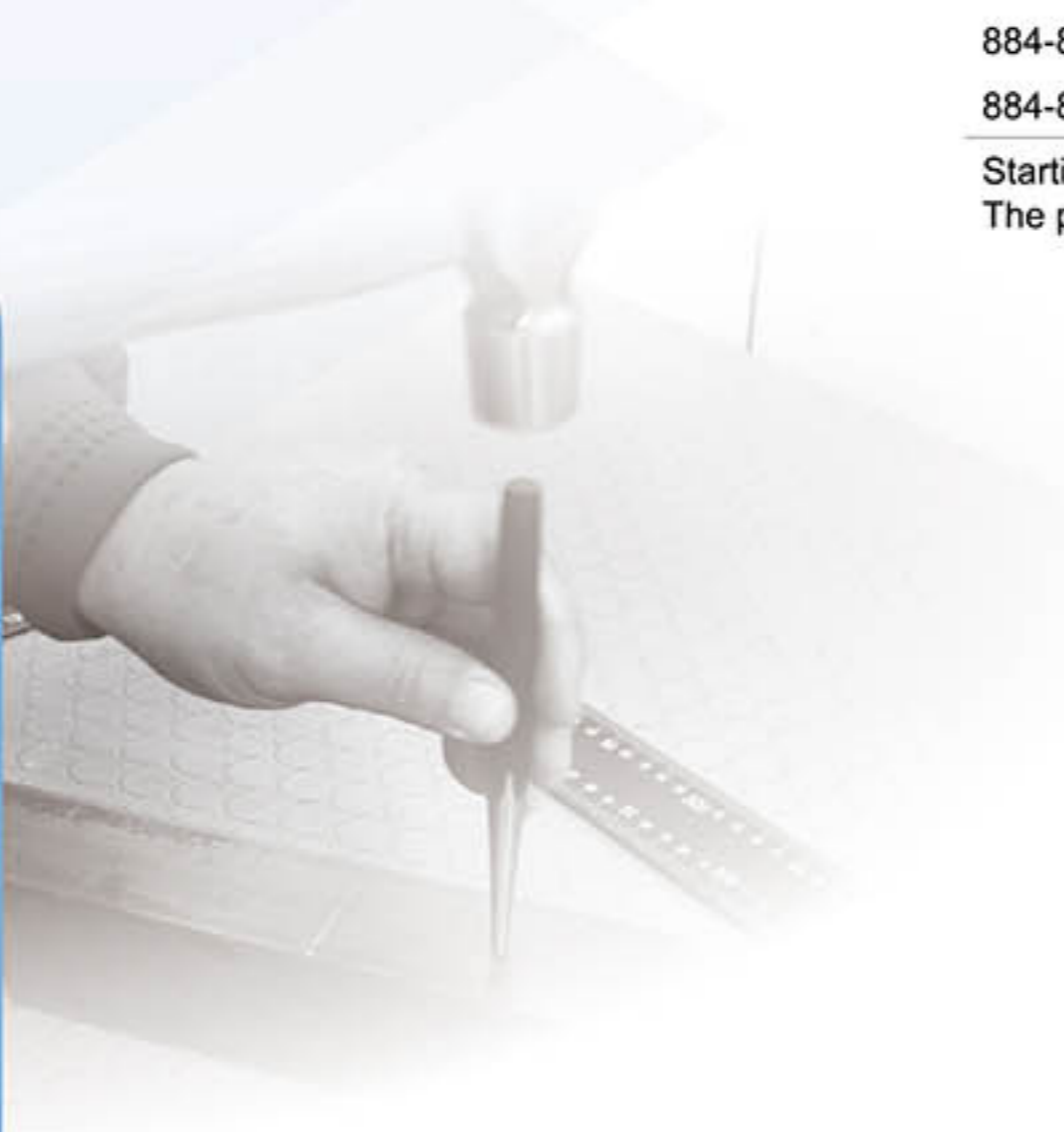
6 Pc. Pin Punch Set

Item No.			KGS
884-650	Metric	5	2.9

- Pin Punch :
2.0 x 8 x 115 mm, 3.0 x 8 x 125 mm, 4.0 x 9.5 x 150 mm, 5.0 x 9.5 x 165 mm,
6.0 x 12.7 x 180 mm, 8.0 x 12.7 x 180 mm

Cr-V Steel, Mn. Phosphate, ABS Holder

7 Pc. Pin Punch Set

Item No.			KGS
884-612	SAE	1	0.4

- Pin Punch :
1/16" x 1/4" x 4-1/4", 3/32" x 1/4" x 4-1/4", 1/8" x 5/16" x 4-3/4", 5/32" x 3/8" x 5",
3/16" x 3/8" x 5-1/4", 1/4" x 3/8" x 5-3/4", 5/16" x 1/2" x 6-1/4"

Cr-V Steel, Mn. Phosphate, PVC Hanging Bag



8 Pc. Pin Punch Set

Item No.			KGS
884-610	SAE	1	0.7
<ul style="list-style-type: none"> ● Solid Punch : 3/16" ● Pin Punch : 1/8", 3/16", 1/4" ● Center Punch : 5/32" ● Cold Flat Chisel : 1/2", 5/8", 3/4" 			
PVC Hanging Bag			



12 Pc. Pin Punch Set

Item No.			KGS
884-600	SAE	1	1.1
<ul style="list-style-type: none"> ● Pin Punch : 3/32", 1/8", 5/32", 3/16", 1/4", 5/16" ● Starting Punch : 3/32", 1/8", 5/32", 3/16", 1/4", 5/16" 			
PVC Hanging Bag			



16 Pc. Pin Punch Set

Item No.			KGS
884-611	SAE	1	1.5
<ul style="list-style-type: none"> ● Solid Punch : 1/8", 3/16", 1/4" ● Pin Punch : 1/8", 3/16", 1/4" ● Center Punch : 1/8", 5/32", 1/4" ● Aligning Punch : 3/16", 1/4" ● Cold Flat Chisel : 5/16", 1/2", 5/8", 3/4", 7/8" 			
PVC Hanging Bag			



17 Pc. Power Punch Kit

Item No.			KGS
884-606	SAE	1	1.5
<ul style="list-style-type: none"> ● 7 Sets of Punches & Dies : 3/32", 1/8", 5/32", 3/16", 7/32", 1/4", 9/32" 			
Metal-Punching Tool Set, Various Models Available for Different Combinations.			



■ Measuring Tape (Dual Lock, Double Sided)

Item No.	Length	Blade Width		KGS
961-003	3.0 m / 10 ft	16 mm	12	1.6
961-005	5.0 m / 16 ft	19 mm	12	2.9
961-006	5.5 m / 18 ft	25 mm	6	1.6
961-007	7.5 m / 25 ft	25 mm	6	2.3
961-008	8.0 m / 25 ft	25 mm	6	2.7

■ Measuring Tape (Self-Lock)

Item No.	Length	Blade Width		KGS
961-103	3.0 m / 10 ft	16 mm	12	1.4
961-105	5.0 m / 16 ft	19 mm	12	2.6
961-106	5.5 m / 18 ft	25 mm	6	1.8
961-107	7.5 m / 25 ft	25 mm	6	2.5
961-108	8.0 m / 25 ft	25 mm	6	2.5

■ 7 Pc. Thickness Gauge

Item No.		KGS
968-557	20	0.6

Size : 0.03, 0.05, 0.06, 0.10, 0.25, 0.60, 0.70 mm

■ 13 Pc. Thickness Gauge

Item No.		KGS
968-563	20	1.1

Size : 0.05, 0.10, 0.15, 0.20, 0.25, 0.30, 0.40, 0.50, 0.60, 0.70, 0.80, 0.90, 1.00 mm



■ Heavy Duty C Clamp

Item No.	Size	Throat Depth		KGS
968-623	3"	70 mm	4	4.0
968-624	4"	75 mm	6	8.2
968-626	6"	100 mm	4	8.8
968-628	8"	125 mm	2	6.3
968-630	10"	150 mm	1	5.7
968-632	12"	170 mm	1	6.0

A: Size
B: Throat Depth

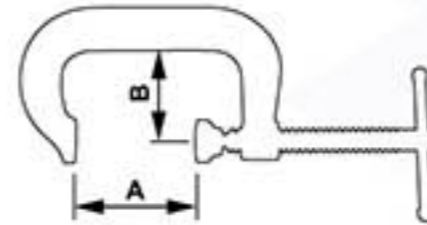

■ F Clamp with Steel Handle

Item No.	Capacity	Throat Depth		KGS
968-648	8"	120 mm	1	2.2
968-650	10"	120 mm	1	2.3
968-652	12"	120 mm	1	2.5
968-656	16"	120 mm	1	2.7
968-660	20"	120 mm	1	3.2
968-664	24"	120 mm	1	3.5
968-666	36"	120 mm	1	4.7

A: Capacity
B: Throat Depth

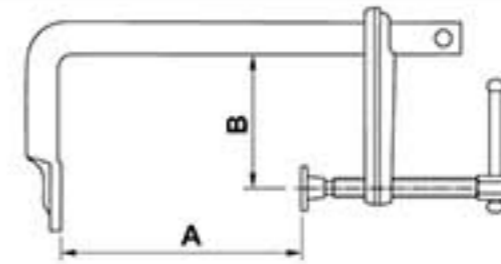

■ Gear Puller – 2 Jaw

Item No.	Size		KGS
982-003	3"	20	9.5
982-004	4"	16	13.4
982-006	6"	8	15.4
982-008	8"	4	15.6
982-010	10"	4	15.5
982-012	12"	2	17.0



■ Gear Puller – 3 Jaw

Item No.	Size		KGS
983-003	3"	20	10.0
983-004	4"	16	18.0
983-006	6"	8	21.0
983-008	8"	4	20.5
983-010	10"	3	25.0
983-012	12"	2	22.0

Bearing Extractor

Item No.	Capacity	Bolt	Body Throat		KGS
882-102	13/16" - 25/35" (20mm x 40mm)	6.35mm x L64mm x 1/4" x 20UNF	1/4"x20UNC	30	7.0
882-103	1-1/4" - 2-1/4" (30mm x 50mm)	9.5mm x L125mm x 3/8" x 24UNF	3/8"x16UNC	20	13.0
882-104	2-1/4" - 3-1/2" (50mm x 75mm)	12.7mm x L135mm x 1/2" x 20UNF	3/8"x16UNC	10	15.0
882-203	3" - 4-1/4" (75mm x 105mm)	16mm x L165mm x 5/8" x 18UNF	1/2"x13UNC	6	16.0
882-204	4" - 6" (100mm x 150mm)	19mm x L260mm x 3/4" x 16UNF	5/8"x11UNC	5	26.0
882-205	6" - 8" (150mm x 200mm)	25.4mm" x L350mm x 1" x 12UNF	3/4"x10UNC	2	22.4

S45C Hardened 42° - 45°



Combination Gear & Bearing Extractors Tool Set

Item No.		KGS
895-043	1	5.5

- Small Bearing Extractors
Jaw Range : 30-50mm
Working Range : 0-135mm
- Large Bearing Extractors
Jaw Range : 50-75mm
Working Range : 0-180mm
- Includes Centre Adapter

- Excellent fit and finish with total reliability
- Drop forged hardened bearing extractors S45C
- Super high quality for trade and industrial usage
- Injection molded case captures extension rods in the lid, for versatile and compact storage

Chain Wrench

Item No.	Size		KGS
995-906	6"	6	2.5
995-909	9"	6	3.2
995-912	12"	6	4.5



Oil Filter Wrench

Item No.	Size		KGS
972-011	3"	24	15.3

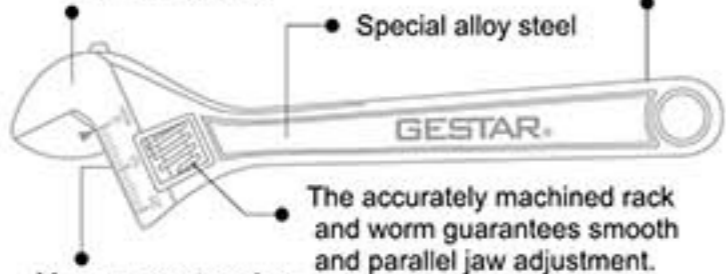

Slim jaws are shaped to give the best possible entry into confined spaces.

Ergonomic handle is wider for more comfortable grip.



Measurement scales are handy for sizing nuts, pipe and tube diameters.

The accurately machined rack and worm guarantees smooth and parallel jaw adjustment.

Special alloy steel

Adjustable Wrench

Item No.	Size		KGS
995-604	4"	6	0.3
995-606	6"	6	1.1
995-608	8"	6	1.8
995-610	10"	6	3.0
995-612	12"	6	4.6
995-615	15"	1	1.5
995-618	18"	1	2.2
995-624	24"	1	3.6



Heavy Duty Pipe Wrench

Item No.	Size		KGS
995-708	8"	6	3.0
995-710	10"	6	4.2
995-712	12"	6	5.8
995-714	14"	6	7.6
995-718	18"	4	7.0
995-724	24"	2	5.7
995-736	36"	1	5.4
995-748	48"	1	8.0



Heavy Duty Aluminum Pipe Wrench

Item No.	Size		KGS
995-775	10"	6	3.4
995-776	12"	6	5.0
995-777	14"	6	6.0
995-779	18"	2	3.0
995-780	24"	2	5.5
995-781	36"	1	5.2
995-782	48"	1	8.6

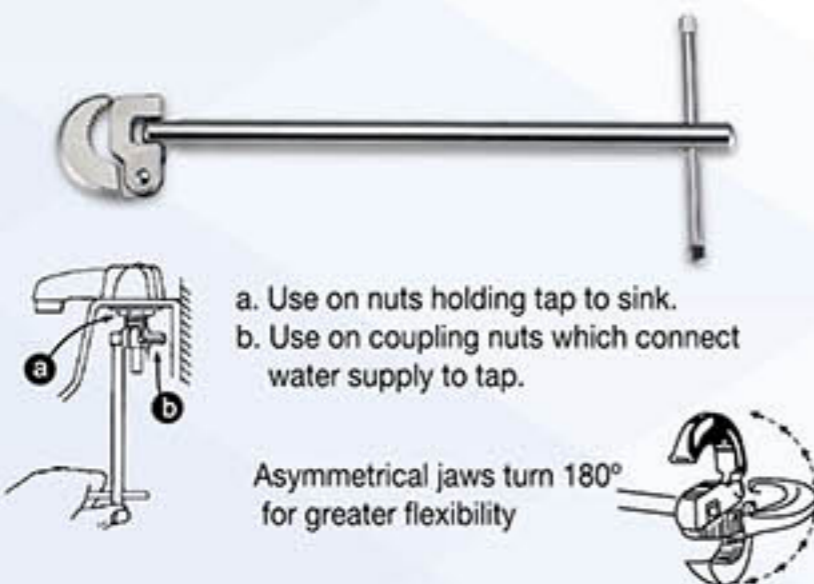

a. Use on nuts holding tap to sink.
b. Use on coupling nuts which connect water supply to tap.

Asymmetrical jaws turn 180° for greater flexibility

Basin Wrench

Item No.	Length		KGS
995-901	11"	10	5.6

Operates at most angles in difficult work areas. Ideal when access is limited on wash basin fittings, ballcocks or flush valves. Suitable for fittings up to 3/4" (19mm)

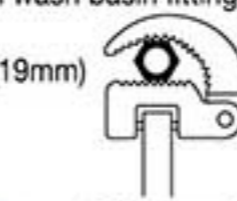

■ Clockwise to tighten



Anti-clockwise to loosen

Standard Riveter

Item No.	Size		KGS
894-309	10"	10	5.7

4 Nozzles : 2.4 mm (3/32"), 3.2 mm (1/8"), 4.0 mm (5/32"), 4.8 mm (3/16")

Rivet Specification	2.4 mm (3/32")	3.2 mm (1/8")	4.0 mm (5/32")	4.8 mm (3/16")
Aluminium	●	●	●	●
Steel	●	●		
Stainless Steel				

Heavy Duty Riveter

Item No.	Size		KGS
894-310	10"	6	3.8

4 Nozzles : 2.4 mm (3/32"), 3.2 mm (1/8"), 4.0 mm (5/32"), 4.8 mm (3/16")

Rivet Specification	2.4 mm (3/32")	3.2 mm (1/8")	4.0 mm (5/32")	4.8 mm (3/16")
Aluminium	●	●	●	●
Steel	●	●	●	
Stainless Steel	●	●		

Heavy Duty Lever Hand Riveter

Item No.	Size		KGS
894-313	19"	12	16.5

Rivet Specification	2.4 mm (3/32")	3.2 mm (1/8")	4.0 mm (5/32")	4.8 mm (3/16")
Aluminium	●	●	●	●
Stainless	●	●		

Heavy Duty Lazy Tong Riveter

Item No.	Size		KGS
994-311	32"	12	20.0

Rivet Specification	2.4 mm (3/32")	3.2 mm (1/8")	4.0 mm (5/32")	4.8 mm (3/16")	6.0 mm (15/64")	6.4 mm (1/4")
Aluminium	●	●	●	●	●	●
Steel	●	●	●	●	●	
Stainless Steel	●	●	●	●		

Heavy Duty Lever Type Riveter

Item No.	Size		KGS
894-312	21"	12	18.0

Rivet Specification	2.4 mm (3/32")	3.2 mm (1/8")	4.0 mm (5/32")	4.8 mm (3/16")	6.0 mm (15/64")	6.4 mm (1/4")
Aluminium	●	●	●	●	●	●
Steel	●	●	●	●	●	
Stainless Steel	●	●	●	●		



■ Staple Gun

Item No.	Staple Size		KGS
894-801	Width : 0.7 mm Leg : 4, 6, 8 mm Crown : 11.3 mm		20 9.0



■ Staple Gun

Item No.	Staple Size		KGS
894-802	Width : 0.7 mm Leg : 4, 6, 8 mm Crown : 11.3 mm		20 9.5

The penetration depth of staples are adjustable.



■ Grease Gun

Item No.	Size		KGS
870-604	400 c.c.		1 1.6



■ Grease Gun

Item No.	Size		KGS
870-605	500 c.c.		1 1.8

Specification
Capacity : 500 c.c. Bulk / 16 oz. Cartridge
Standard Accessory : A-403A



Standard Type
Simple Round
Plug Equipped



Optional
(B) Filler Plug



Variable
Stroke



Bulk
Loading



Cartridge
Loading



Filler Pump Loading
W/ Filler Plug



Working Pressure
3600 psi
Max. Pressure
6000 psi



Delivers Minimum
3 oz. / 40 strokes



Outer Cap
with Stopper

X2 Piston & X3 Volume
Special Design for Truck,
Agricultural Machinery,
and High Volume Device.



■ Air Grease Gun

Item No.	Size		KGS
870-504	400 c.c.		1 1.6

4 Drawer Top Chest \ Ball Bearing Slider

Item No.	Drawer	CUFT	KGS
890-003	4	4.3	23.4

Type	W	D	H
Overall	660 mm (26")	307 mm (12.1")	378 mm (14.9")
3 Drawer	569 mm (22.4")	272 mm (10.7")	50 mm (2")
1 Drawer	569 mm (22.4")	272 mm (10.7")	75 mm (3")

5 Drawer Top Chest \ Ball Bearing Slider

Item No.	Drawer	CUFT	KGS
890-001	5	5	28.8

Type	W	D	H
Overall	660 mm (26")	307 mm (12.1")	433 mm (17")
4 Drawer	569 mm (22.4")	272 mm (10.7")	50 mm (2")
1 Drawer	569 mm (22.4")	272 mm (10.7")	75 mm (3")

6 Drawer Top Chest \ Ball Bearing Slider

Item No.	Drawer	CUFT	KGS
890-004	6	4.5	25.5

Type	W	D	H
Overall	660 mm (26")	307 mm (12.1")	378 mm (14.9")
3 Drawer	169 mm (6.7")	272 mm (10.7")	50 mm (2")
2 Drawer	569 mm (22.4")	272 mm (10.7")	50 mm (2")
1 Drawer	569 mm (22.4")	272 mm (10.7")	75 mm (3")

9 Drawer Top Chest \ Ball Bearing Slider

Item No.	Drawer	CUFT	KGS
890-002	9	5.2	30.7

Type	W	D	H
Overall	660 mm (26")	307 mm (12.1")	433 mm (17")
6 Drawer	169 mm (6.7")	272 mm (10.7")	50 mm (2")
2 Drawer	569 mm (22.4")	272 mm (10.7")	50 mm (2")
1 Drawer	569 mm (22.4")	272 mm (10.7")	75 mm (3")



■ 2 Drawer Portable Tool Chest

Item No.	Drawer	CUFT	KGS
890-015	2	2.05	9.6

Type	W	D	H
Overall	533 mm (21")	220 mm (8.7")	287 mm (11.3")
2 Drawers	504 mm (19.8")	195 mm (7.7")	78.5 mm (3")



■ 3 Drawer Portable Tool Chest

Item No.	Drawer	CUFT	KGS
890-016	3	2.05	11.2

Type	W	D	H
Overall	533 mm (21")	220 mm (8.7")	287 mm (11.3")
3 Drawers	504 mm (19.8")	195 mm (7.7")	51.5 mm (2")



■ 4 Drawer Portable Tool Chest

Item No.	Drawer	CUFT	KGS
890-017	4	2.05	12.2

Type	W	D	H
Overall	533 mm (21")	220 mm (8.7")	287 mm (11.3")
2 Drawers	504 mm (19.8")	195 mm (7.7")	51.5 mm (2")
2 Drawers	237 mm (9.3")	195 mm (7.7")	51.5 mm (2")



■ Tool Box

Item No.	CUFT	KGS
890-022	1.57	5.4

Type	W	D	H
Overall	508 mm (20")	218 mm (8.6")	240 mm (9.4")

■ 2 Drawer Service Cart \ Ball Bearing Slider

Item No.	Drawer	CUFT	KGS
890-011	2	6.92	44.0

Type	W	D	H
Overall	764 mm (30")	520 mm (20.1")	884 mm (34.8")
2 Drawers	628 mm (24.7")	445 mm (17.5")	81 mm (3.2")

■ 4 Drawer Service Cart

Item No.	Drawer	CUFT	KGS
890-010	4	10.82	60.0

Type	W	D	H
Overall	780 mm (30.7")	520 mm (20.5")	1020 mm (40.2")
2 Drawer	298 mm (11.7")	445 mm (17.5")	81 mm (3.2")
1 Drawer	628 mm (24.7")	445 mm (17.5")	81 mm (3.2")
1 Drawer	628 mm (24.7")	445 mm (17.5")	127 mm (5")

■ 1 Drawer 2 Shelf Trolley

Item No.	Drawer	CUFT	KGS
890-013	1	2.7	23.2

Type	W	D	H
Overall	716 mm (28.2")	410 mm (16.1")	750 mm (29.5")
1 Drawer	569 mm (22.4")	275 mm (10.8")	75 mm (3")

■ 3 Shelf Trolley

Item No.	Drawer	CUFT	KGS
890-006	0	3.0	21.3

Type	W	D	H
Overall	716 mm (28.2")	410 mm (16.1")	880 mm (34.6")



■ 6 Drawer Roll Wagon \ Ball Bearing Slider

Item No.	Drawer	CUFT	KGS
890-020	6	13.11	70.7

Type	W	D	H
Overall	670 mm (26.3")	460 mm (18.1")	960 mm (37.7")
3 Drawer	576 mm (22.6")	380 mm (14.9")	75 mm (2.9")
3 Drawer	576 mm (22.6")	380 mm (14.9")	154 mm (6")



■ 7 Drawer Roll Wagon \ Ball Bearing Slider

Item No.	Drawer	CUFT	KGS
890-005	7	12.24	72.0

Type	W	D	H
Overall	680 mm (26.7")	458 mm (18")	995 mm (39.1")
5 Drawer	570 mm (22.4")	406 mm (15.9")	74.5 mm (2.9")
2 Drawer	570 mm (22.4")	406 mm (15.9")	153.5 mm (6")



■ 8 Drawer Roll Wagon \ Ball Bearing Slider

Item No.	Drawer	CUFT	KGS
890-014	8	12.24	74.0

Type	W	D	H
Overall	670 mm (26.3")	460 mm (18.1")	960 mm (37.7")
7 Drawer	576 mm (22.6")	380 mm (14.9")	75 mm (2.9")
1 Drawer	576 mm (22.6")	380 mm (14.9")	154 mm (6")

Shape

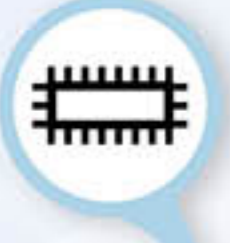

File

Flat File

Item No.	Size		KGS
Rough			
984-202H	6"	10	1.5
984-203H	8"	10	2.0
984-204H	10"	10	2.5
984-205H	12"	10	3.0
984-206H	14"	10	3.5
Middle			
984-212H	6"	10	1.5
984-213H	8"	10	2.0
984-214H	10"	10	2.5
984-215H	12"	10	3.0
984-216H	14"	10	3.5
Fine			
984-222H	6"	10	1.5
984-223H	8"	10	2.0
984-224H	10"	10	2.5
984-225H	12"	10	3.0
984-226H	14"	10	3.5

FLAT FILE

Double-cut on sides, single-cut on edges.
Rectangular in cross section, taper slightly towards point in width.

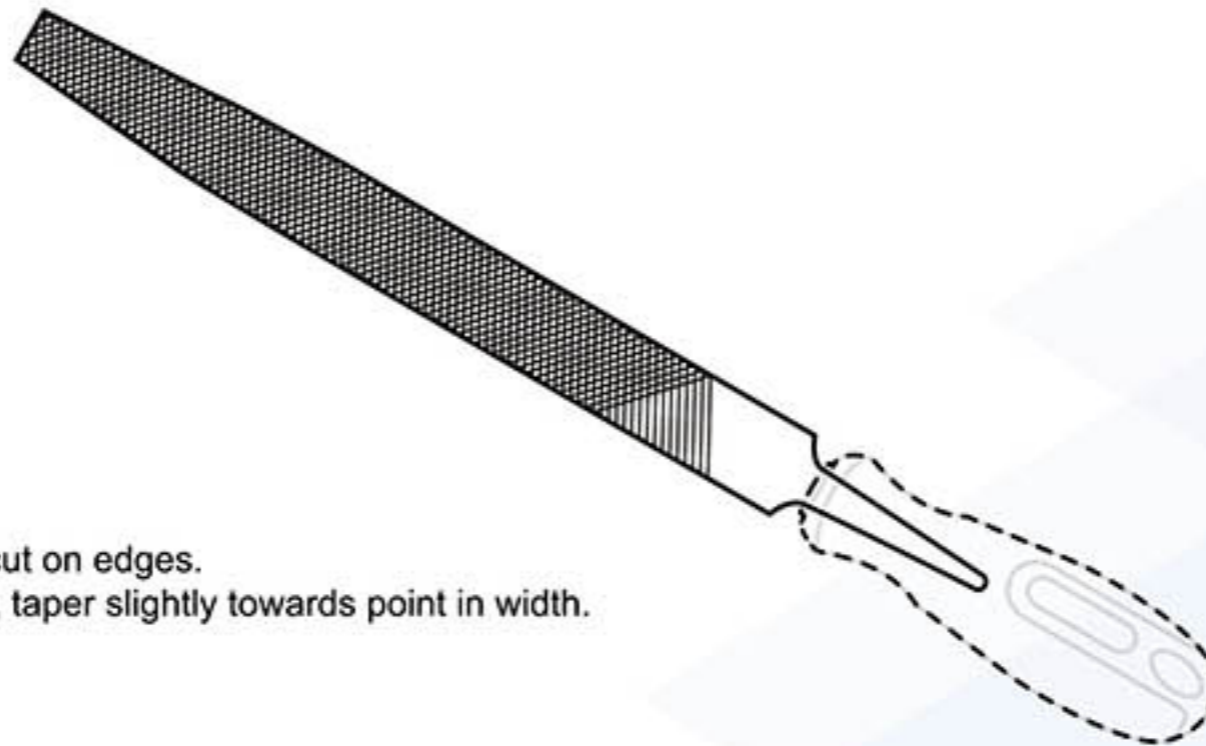

with Plastic Handle

Shape



■ Half Round File

Item No.	Size		KGS
Rough			
984-302H	6"	10	1.5
984-303H	8"	10	2.0
984-304H	10"	10	2.5
984-305H	12"	10	3.0
984-306H	14"	10	3.5
Middle			
984-312H	6"	10	1.5
984-313H	8"	10	2.0
984-314H	10"	10	2.5
984-315H	12"	10	3.0
984-316H	14"	10	3.5
Fine			
984-322H	6"	10	1.5
984-323H	8"	10	2.0
984-324H	10"	10	2.5
984-325H	12"	10	3.0
984-326H	14"	10	3.5

File

HALF ROUND FILE

Round on one side, flat on opposite.
Use on concave, convex and flat surfaces.

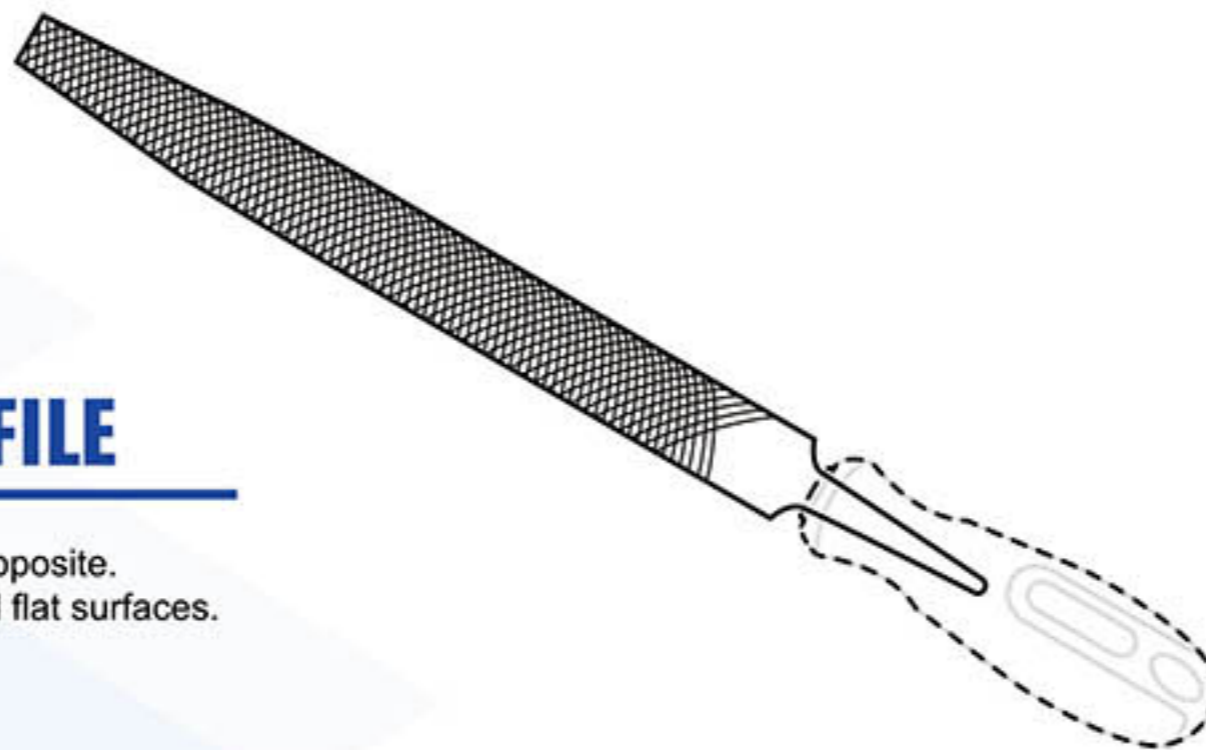

with Plastic Handle

Shape



File

Round File

Item No.	Size		KGS
Rough			
984-402H	6"	10	1.5
984-403H	8"	10	2.0
984-404H	10"	10	2.5
984-405H	12"	10	3.0
984-406H	14"	10	3.5
Middle			
984-412H	6"	10	1.5
984-413H	8"	10	2.0
984-414H	10"	10	2.5
984-415H	12"	10	3.0
984-416H	14"	10	3.5
Fine			
984-422H	6"	10	1.5
984-423H	8"	10	2.0
984-424H	10"	10	2.5
984-425H	12"	10	3.0
984-426H	14"	10	3.5

ROUND FILE

Round Cross Section, Single-cut (Except For 14" Bastard) and Slightly Tapered Towards Point. Primarily Used To File Circular Openings Or Concave Surfaces.

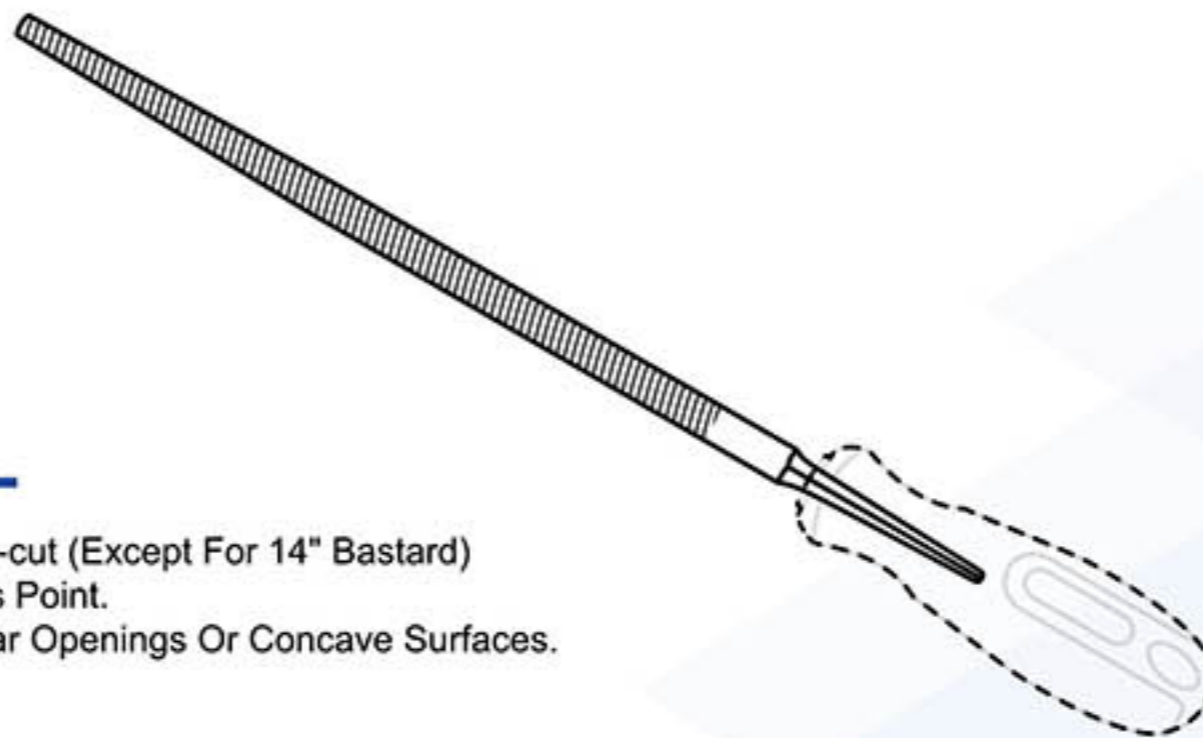

with Plastic Handle

Shape



Triangular File

Item No.	Size		KGS
Rough			
984-501	4"	10	0.5
984-502	6"	10	1.5
984-503	8"	10	2.0
984-504	10"	10	2.5
984-505	12"	10	3.0
984-506	14"	10	3.5
Middle			
984-511	4"	10	0.5
984-512	6"	10	1.5
984-513	8"	10	2.0
984-514	10"	10	2.5
984-515	12"	10	3.0
984-516	14"	10	3.5
Fine			
984-521	4"	10	0.5
984-522	6"	10	1.5
984-523	8"	10	2.0
984-524	10"	10	2.5
984-525	12"	10	3.0
984-526	14"	10	3.5

File

TRIANGULAR FILE

Single-Cut.
Made for Filing Saws with 60° Angle Teeth, Axes and Machetes.

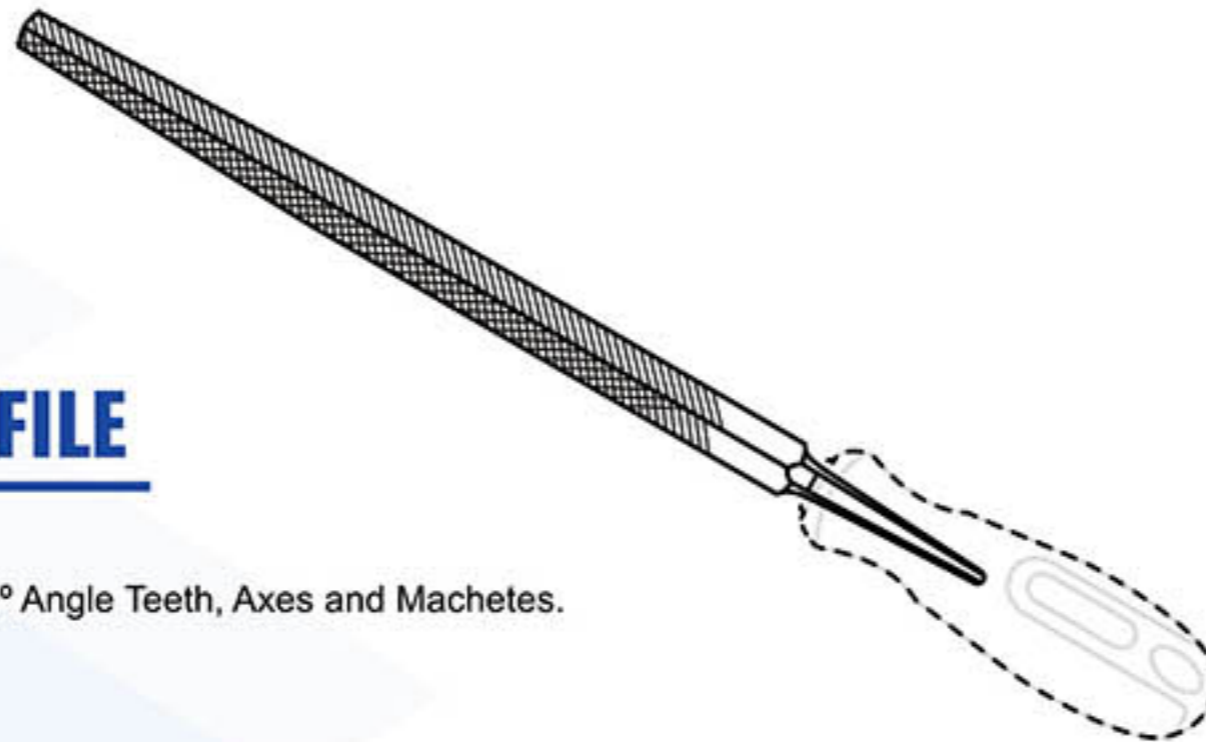

with Plastic Handle